

100C411-CR -63

Bend model:
BEND100-100 ANSI

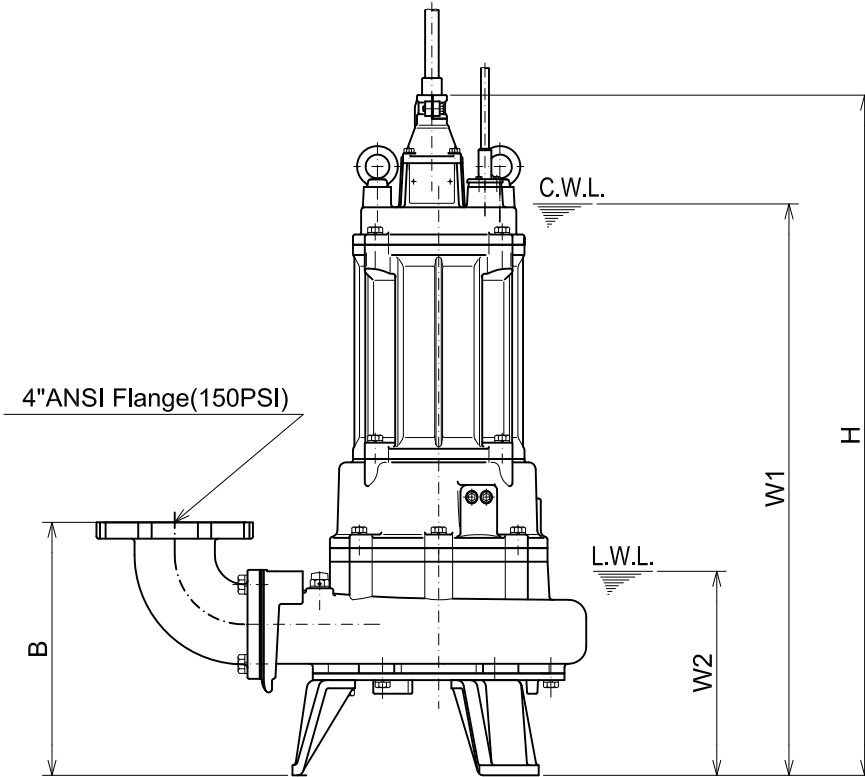
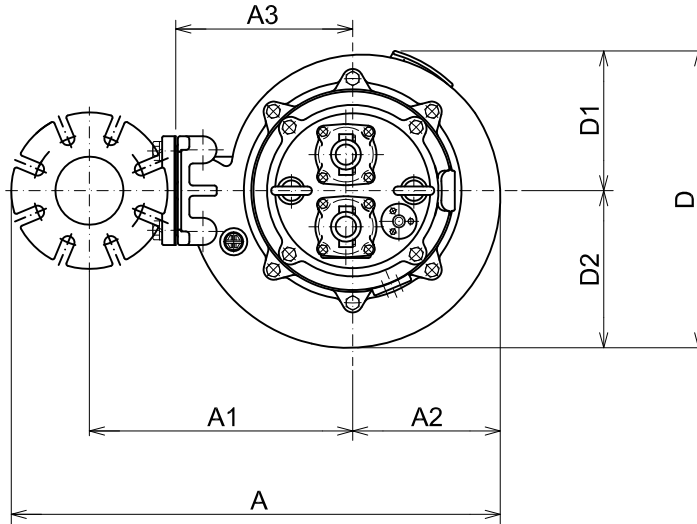

C.W.L. : Continuous running Water Level
L.W.L. : Lowest running Water Level

DIMENSIONS:USCS(Inch)

Model	HP	NOM. SIZE	Pump & Motor									C.W.L.	L.W.L.	*Wt. (lbs.)
			A	A1	A2	A3	B	D	D1	D2	H			
100C411-CR -63	15	4"	28 3/4	15 11/16	8 9/16	10 1/4	14 5/8	16 15/16	7 7/8	9 1/8	39 3/8	33 1/8	11 3/4	395

DIMENSIONS:METRIC(mm)

Model	kW	NOM. SIZE	Pump & Motor									C.W.L.	L.W.L.	*Wt. (kg)
			A	A1	A2	A3	B	D	D1	D2	H			
100C411-CR -63	11	100	730	398	217	260	372	431	200	231	1000	840	300	179

*Excluding Cable.



TSURUMI PUMP

**C-SERIES
CUTTER - TYPE - SEWAGE & WASTEWATER PUMPS**

DIMENSIONS

TOS100C411-CR -63

Guide Rail System
Model : TOS3-100-100 ANSI
Wt. : 108lb. (49kg)

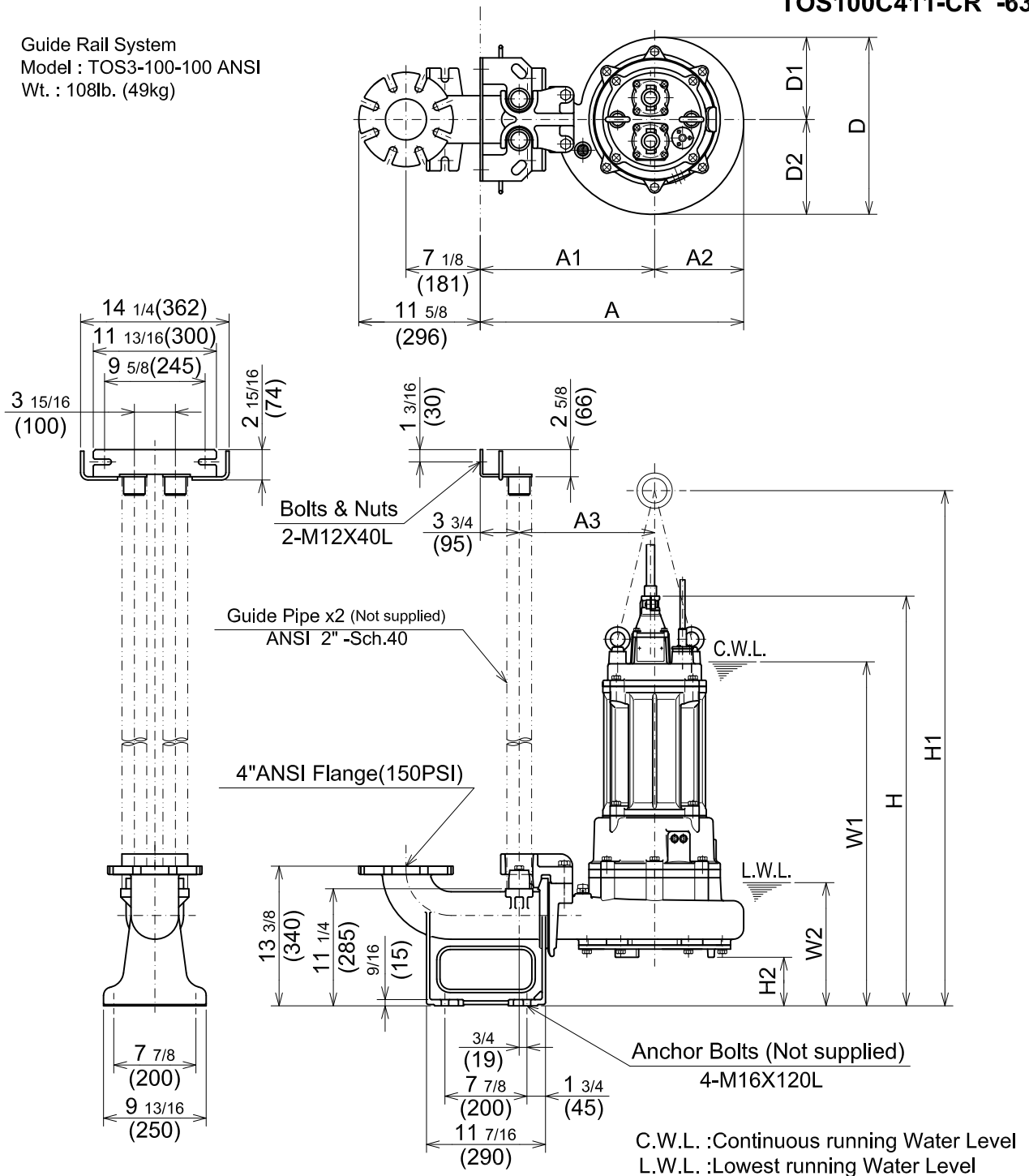

DIMENSIONS:USCS(Inch)

Model	HP	NOM. SIZE	Pump & Motor									C.W.L.	L.W.L.	*Wt. (lbs.)	
			A	A1	A2	A3	D	D1	D2	H	H1				H2
TOS100C411-CR -63	15	4"	25 1/4	16 3/4	8 9/16	13	16 15/16	7 7/8	9 1/8	39 5/16	52 3/8	4 5/8	33 1/8	11 3/4	390

DIMENSIONS:METRIC(mm)

Model	kW	NOM. SIZE	Pump & Motor									C.W.L.	L.W.L.	*Wt. (kg)	
			A	A1	A2	A3	D	D1	D2	H	H1				H2
TOS100C411-CR -63	11	100	642	425	217	330	431	200	231	998	1329	118	840	300	177

*Excluding TOS & Cable.



**C-SERIES
CUTTER - TYPE - SEWAGE & WASTEWATER PUMPS**

**PERFORMANCE
CURVE**

MODEL	BORE	HP	KW	RPM	SOLIDS DIA.	LIQUID	SG.	VISCOSITY	TEMP.
(TOS)100C411-CR -63	4"/100mm	15	11	1733	1.97"/50mm	Water	1.0	1.123cSt.	60°F
PUMP TYPE	PHASE	VOLTAGE	AMPERAGE	HZ	STARTING METHOD	INS.CLASS			
Cutter-Type-Sewage&Wastewater	3	208-230/460/575	42.2-39.2 / 19.5 / 15.7	60	Star-Delta	F			
CURVE No.	DATE	PHASE	VOLTAGE	AMPERAGE	HZ	STARTING METHOD	INS.CLASS		
-	-	-	-	-	-	-	-		

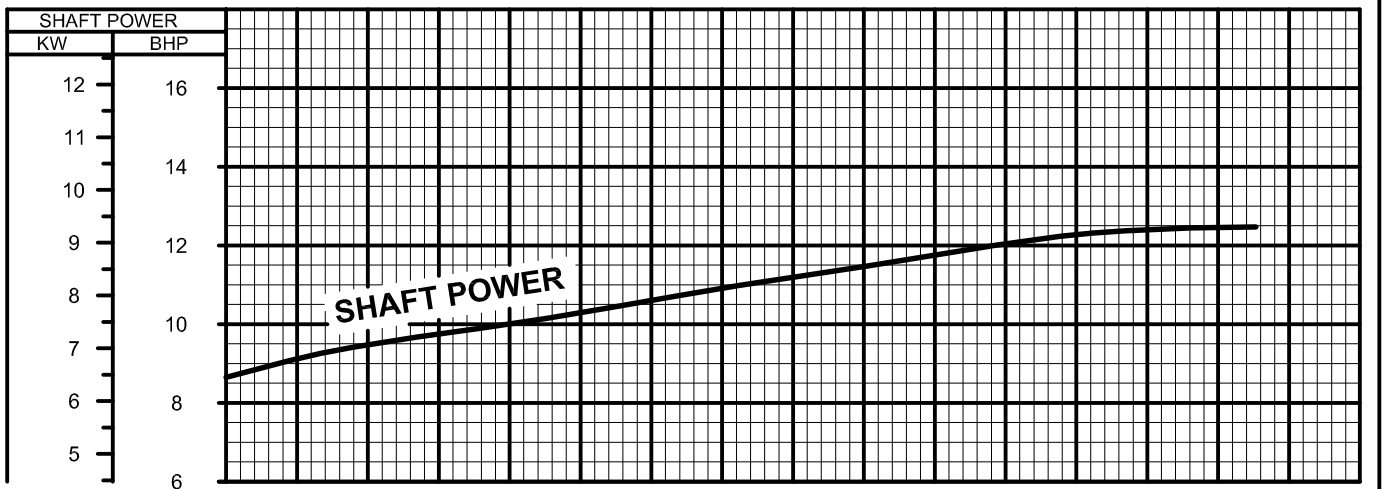
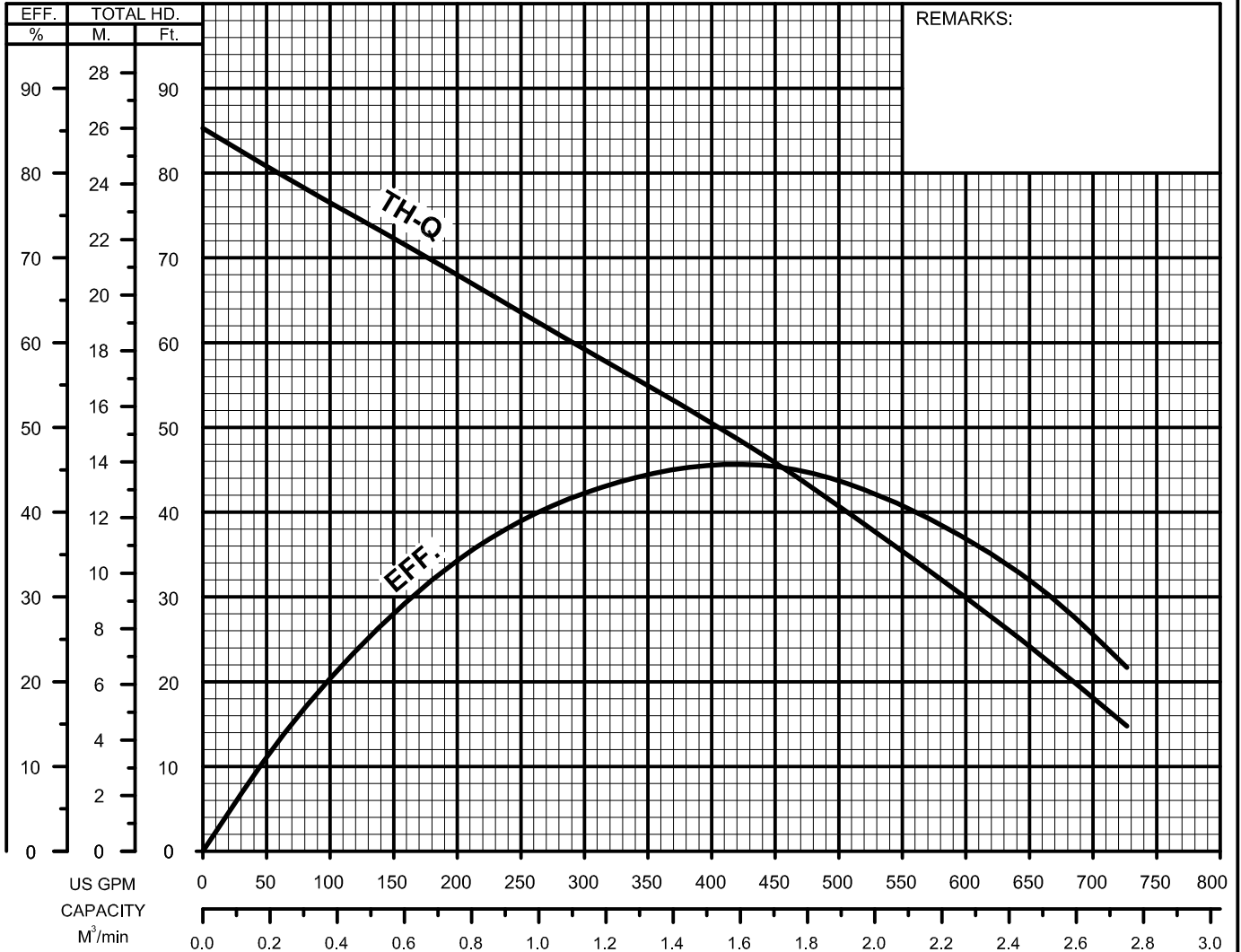



TSURUMI PUMP

**C-SERIES
CUTTER - TYPE - SEWAGE & WASTEWATER PUMPS**

SECTIONAL VIEW

100C411-CR -63

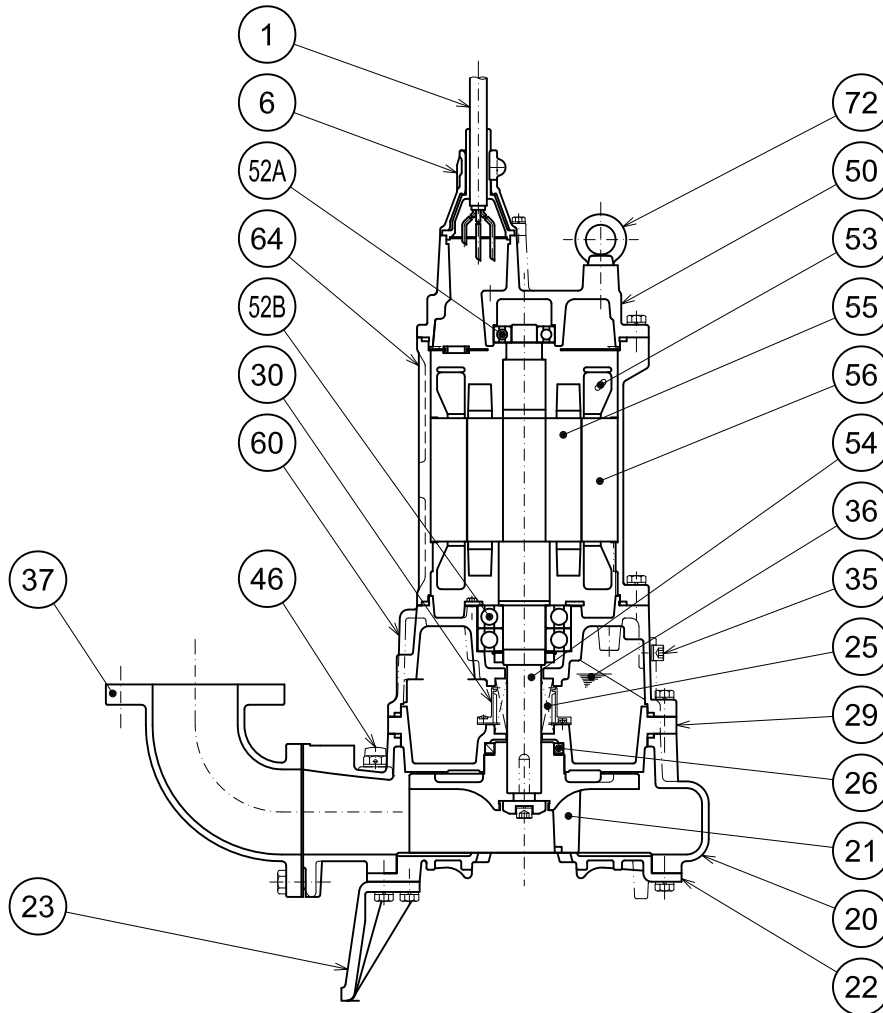

PART#	DESCRIPTION	MAIN MATERIAL / NOTE	RELATED ASTM,AISI CODE	RELATED EN CODE	QTY
1	Power Cable	Chloroprene Sheath AWG 12/4-32ft			1
	Power Cable	Chloroprene Sheath AWG 12/3-32ft			1
	Control Cable	Chloroprene Sheath AWG 16/2-32ft			1
6	Stuffing Box	Cast Iron	A48M Class30B	EN 1561 GJL-200	2
20	Pump Casing	Cast Iron	A48M Class30B	EN 1561 GJL-200	1
21	Impeller	Cast Iron W/Tungsten Carbide	A48M Class30B	EN 1561 GJL-200	1
22	Suction Cover	High Chrome Cast Iron	A532 Class III TypeA	DIN 1695 G-X260Cr27	1
23	Pump Stand	Cast Iron	A48M Class30B	EN 1561 GJL-200	3
25	Mechanical Seal	Silicon Carbide / H-40			1
26	Oil Seal	NBR / TC709212			1
29	Oil Casing	Cast Iron	A48M Class30B	EN 1561 GJL-200	1
30	Oil Lifter	PBT Resin W/GF40			1
35	Oil Plug	Stainless Steel	S 30400	1.4301	2
36	Lubricant	Turbine Oil ISO VG32 or SAE 10W-20			
37	Discharge Bend	Cast Iron / 4"ANSI Flange(150PSI)	A48M Class30B	EN 1561 GJL-200	1
46	Air Release Valve	Nylon			1
50	Motor Bracket	Cast Iron	A48M Class30B	EN 1561 GJL-200	1
52A	Upper Bearing	AC-#6306ZZC3			1
52B	Lower Bearing	#6310ZZD2C3			1
53	Motor Protector				3
54	Shaft	Stainless Steel	S 42000	1.4028	1
55	Rotor				1
56	Stator				1
60	Bearing Housing	Cast Iron	A48M Class30B	EN 1561 GJL-200	1
64	Motor Housing	Cast Iron	A48M Class30B	EN 1561 GJL-200	1
72	Lifting Lug Bolt	Steel	A283 Grade D	EN 10025 S275	2

PARTS LIST		SEWAGE & WASTEWATER PUMPS			2/5/2018	
ITEM	PART No.	DESCRIPTION	QTY	SIZE	MATERIAL	NOTES
1	009-127-14	Terminal	2	R-1.25-4	CU	
2	140-018-11	Hex.Bolt	3	M5x15	SUS304	
3	142-422-18	Seal Washer	3	PM-5	SUS+NBR	
4	003-111-20	Gland	1		SUS304	
5	001-005-66	Cabtyre Cable Set (32') (USA)	1	2PNCT2Cx1.25mm2	BE/CE	
6	009-274-17	Terminal	2	TMNB-2(Insulated)		
7	009-131-11	Terminal	7	R-5.5-6	CU	
8	140-055-10	Hex.Bolt	8	M8x25	SUS304	
9	142-163-18	Spring Washer	8	M8	SUS304	
10	070-107-18	Cable Clamp	2		FC	included in ITEM# 13 Cable Ass'y
11	140-035-14	Hex.Bolt	4	M6x20	SUS304	included in ITEM# 13 Cable Ass'y
12	006-126-14	Stuffing Box	2	No.2	FC	included in ITEM# 13 Cable Ass'y
13	001-937-24	Cabtyre Cable Set (32') (USA)	1	2PNCT3Cx3.5mm2	KR-2	
14	008-154-17	Mould Cover	1	KR2-10	CR	included in ITEM# 13 Cable Ass'y
15	009-275-18	Compression type Terminal	6	TGNB-5.5(Insulated)	CU	included in ITEM# 13 Cable Ass'y
16	001-936-23	Cabtyre Cable Set (32') (USA)	1	2PNCT4Cx3.5mm2	KR-2	
17	008-142-12	Mould Cover (USA)	1	KR2-7	CR	included in ITEM# 16 Cable Ass'y
18	143-085-21	Pan Screw (w/Spring Washer)	1	M4x6	SWRM	
19	009-122-19	Terminal	1	R-3.5-4	CU	included in ITEM# 16 Cable Ass'y
20	072-107-14	Eye Bolt	2	M16	SS	can substitute 072-107-27 (SUS304)
	142-399-15	Washer		d17xd29x0.1t	SUS304	
	142-400-10	Washer		d17xd29x0.3t	SUS304	
21	140-098-15	Hex.Bolt	4	M12x35	SUS304	
22	142-165-10	Spring Washer	4	M12	SUS304	
23	050-000-80	Motor Bracket	1		FC	
24	122-173-19	O-Ring	1	V-225(222.5xd6)	NBR	*
25	142-000-08	Wave Washer	1	6306B(d71xd59x4.0t)	SK5	
26	052-000-25	Bearing (w/O-ring)	1	AC-6306ZZC3		
27	058-000-09	Lead Wire Protection Plate	1	d86xd224x1.6t	SPHC	
28	055-000-69	Rotor	1Set			
29	147-011-15	Impeller Key	1	12x8x40	SUS420	
30	053-310-13	Motor Protector	3	9700K-76-215	(H)	
31	056-B91-15	Stator 208/230V-60HZ(USA)	1Set			
	056-B92-16	Stator 460V-60HZ(USA)	1Set			
	056-B95-19	Stator 575V-60HZ(USA)	1Set			
32	064-000-12	Motor Frame	1		FC	
33	140-100-11	Hex.Bolt	4	M12x45	SUS304	
34	142-165-10	Spring Washer	4	M12	SUS304	

PARTS LIST		SEWAGE & WASTEWATER PUMPS			2/5/2018	
ITEM	PART No.	DESCRIPTION	QTY	SIZE	MATERIAL	NOTES
35	122-173-19	O-Ring	1	V-225(222.5xd6)	NBR	*
36	140-032-37	Hex.Bolt	3	M6x15	SWRM	
37	062-224-17	Bearing Fixing Plate	1	d98xd140x4.5t	SS	
38	052-141-18	Bearing	1Set	6310ZZD2C3		
39	142-000-09	Bearing Washer	1	50x61x74x1.2t	SUS	
40	141-000-03	Bearing Nut	1	70x2.5x11	SUS304	
41	060-431-13	Bearing Housing	1		FC	
42	121-247-12	Packing	2	d12.3xd18x2t	PE	*
43	035-113-18	Oil Plug	2	M12x14	SUS304	
44	140-099-16	Hex.Bolt	2	M12x40	SUS304	
45	142-165-10	Spring Washer	2	M12	SUS304	
46	140-104-15	Hex.Bolt	4	M12x65	SUS304	
47	142-165-10	Spring Washer	4	M12	SUS304	
48	025-000-61	Mechanical Seal	1	H-40X(E)	SiC	
49	143-070-23	Pan Screw	2	M5x6	SWRM	
50	030-141-10	Oil Lifter	1	H-40(T)	Resin	
51	143-070-10	Pan Screw	3	M5x6	SWRM	
52	030-149-18	Seal Stopper	1	H-40/45	SPCC	
53	122-159-19	O-Ring	1	G-280(279.3xd5.7)	NBR	*
54	029-191-11	Oil Casing	1	110-CE2	FC	
55	122-159-19	O-Ring	1	G-280(279.3xd5.7)	NBR	*
56	026-117-14	Oil Seal	1	TC-709212	NBR	
57	040-124-18	Impeller Shim		d25.2xd35x0.3t	SUS304	
58	021-840-18	Impeller (60Hz) 1st	1	100C411-CR-63	FC	
	021-010-16	Impeller (60Hz) 2nd	1	100C411-CR-63	FC	
59	144-530-16	Hex.Socket Set Screw	2	M6x15	SUS304	
60	142-202-10	Impeller Fixing Washer	1	d13xd50x15t	SUS304	
61	142-000-22	Spring Washer	1	M12(CP)	SUS304	
62	140-304-17	Hex.Socket Cap Bolt	1	M12x45	SUS304	
63	046-107-13	Air Release Valve	1	PT-1/2	Nylon	
64	020-539-18	Pump Casing	1	110-USH/USL	FC	
65	120-102-11	Packing (S.Cover)		d301xd328x0.3t	PE	
66	022B5017	Suction Cover	1	55/110-CE2	HiCrFC	
67	142-165-10	Spring Washer	3	M12	SUS304	
68	140-097-14	Hex.Bolt	3	M12x30	SUS304	
	173-001-22	Packing O-Ring Set	1Set	(Marked by *)		
24	122-173-19	O-Ring (M.Bracket/M.Frame)	1	V-225(222.5xd6)	NBR	*
35	122-173-19	O-Ring (M.Frame/Brg.Housing)	1	V-225(222.5xd6)	NBR	*



MODEL 100C411-CR-63

PARTS LIST		SEWAGE & WASTEWATER PUMPS			2/5/2018	
ITEM	PART No.	DESCRIPTION	QTY	SIZE	MATERIAL	NOTES
42	121-247-12	Packing (Oil Plug)	2	d12.3xd18x2t	PE	*
53	122-159-19	O-Ring (Brq.Housing/O.Casing)	1	G-280(279.3xd5.7)	NBR	*
55	122-159-19	O-Ring (O.Casing/P.Casing)	1	G-280(279.3xd5.7)	NBR	*
		Lubricant		Turbine Oil VG32 6,400ml		
	183-013-19	Impeller Puller	1	BE No.13 2"	SGPSS	

PARTS LIST		SEWAGE & WASTEWATER PUMPS			2/5/2018	
ITEM	PART No.	DESCRIPTION	QTY	SIZE	MATERIAL	NOTES

EXPLODED VIEW

100C411-CR-63

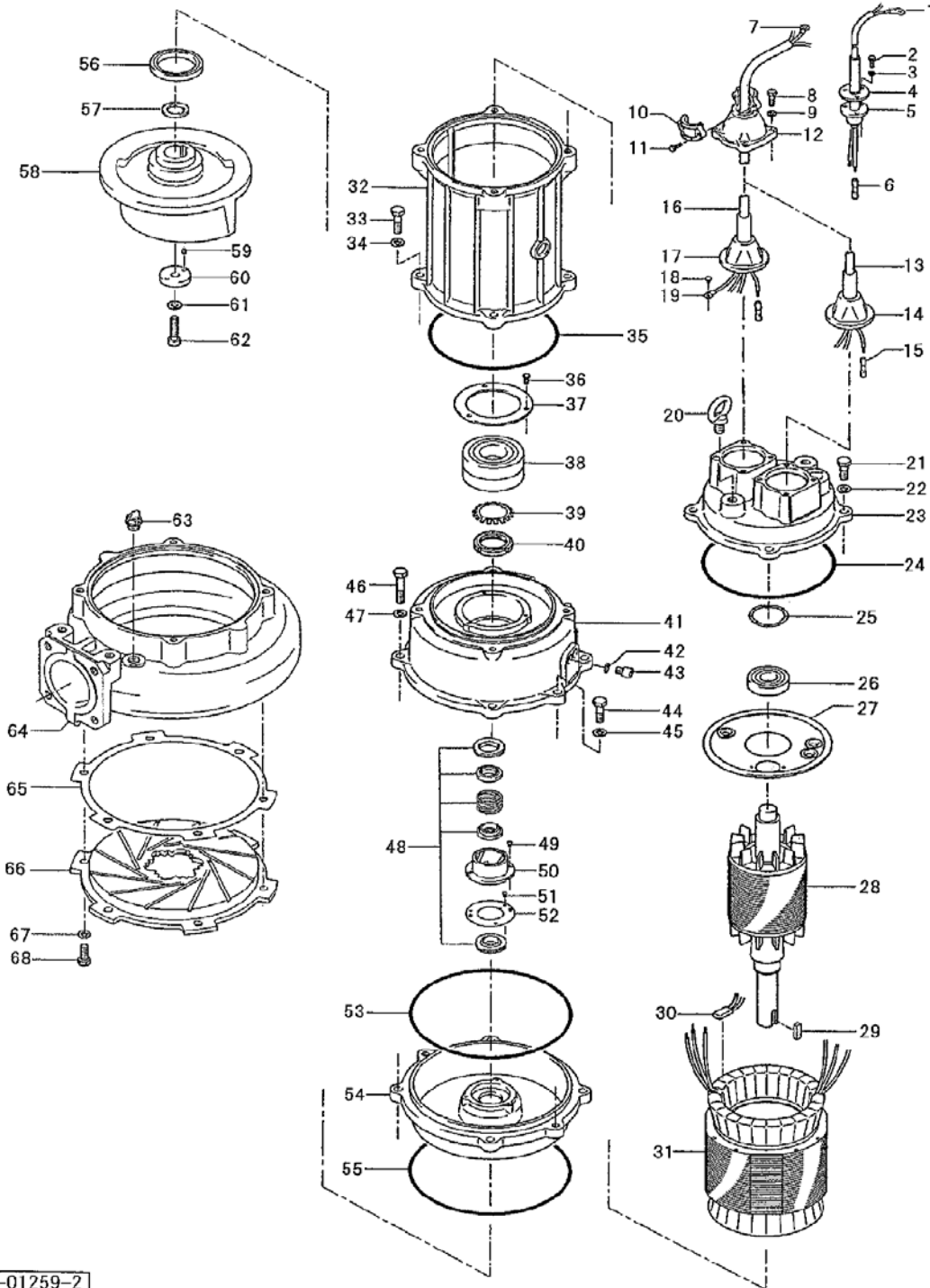

C-01259-2